

UNCONTROLLED IF PRINTED; CONTROLLED DOCUMENT LOCATED IN IQMS DOCUMENT CONTROL

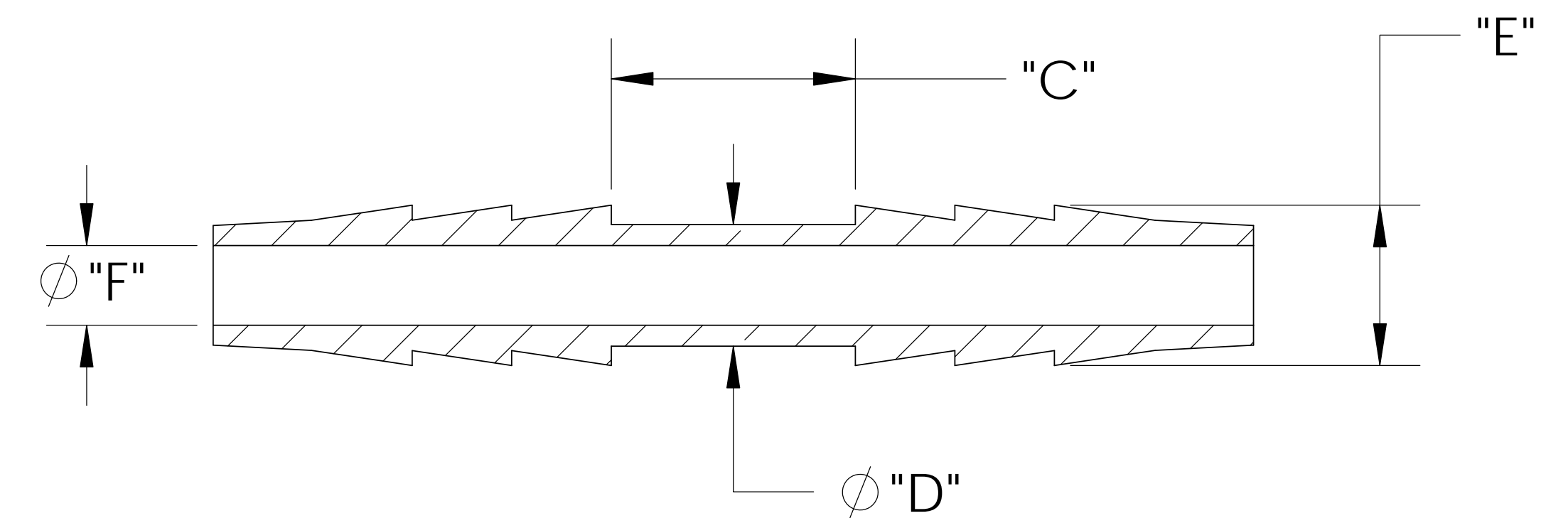
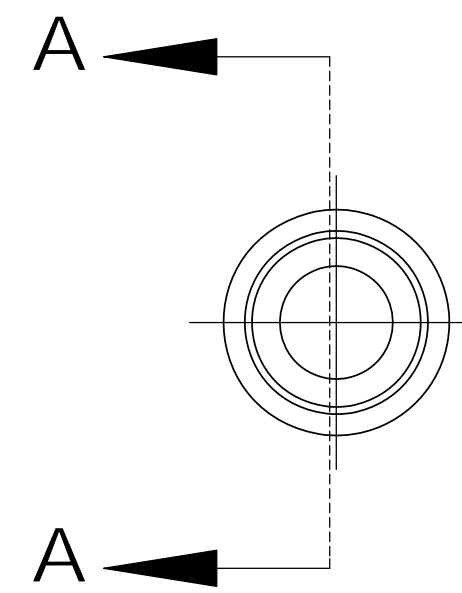
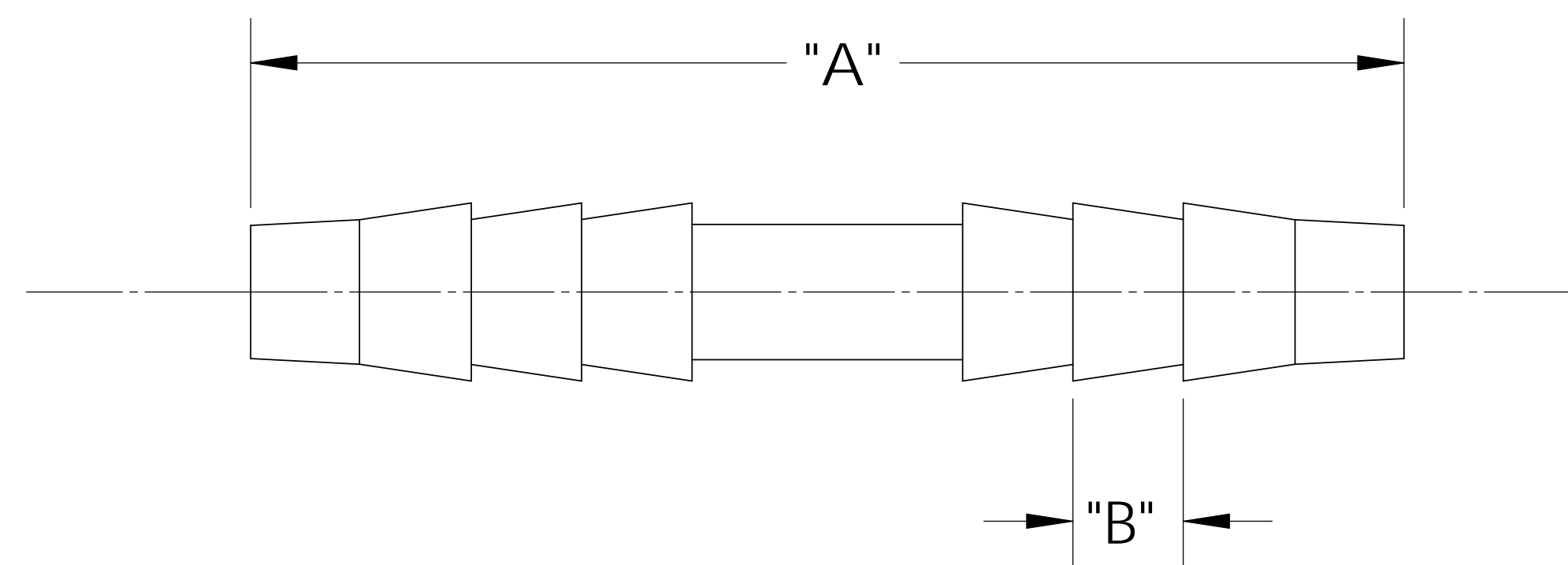
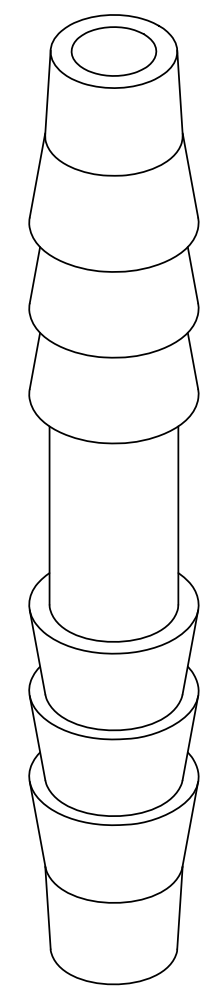

SECTION A-A

CATALOG NO.	DESCRIPTION	MATERIAL	DIM "A"	DIM "B"	DIM "C"	DIM "D"	DIM "E"	DIM "F"
TC71010/PP	5/8 X 5/8 PP	POLYPROPYLENE	1.72	.155	.485	.600	.660	.460
TC71010/P	5/8 X 5/8 P	POLYETHYLENE	1.69	.150	.475	.605	.655	.450
TC71010/N	5/8 X 5/8 N	NYLON	1.74	.155	.500	.605	.670	.470
TC71010/K	5/8 X 5/8 K	KYNAR	1.74	.155	.500	.605	.670	.470

SHOWN

NOTES:

- POLYPROPYLENE HAS COLOR OPTIONS:  
BLACK = TC71010/PPB  
NATURAL = TC71010/PPN

**PROPRIETARY AND CONFIDENTIAL**  
THE INFORMATION CONTAINED IN THIS DRAWING IS THE SOLE PROPERTY OF THOGUS PRODUCTS COMPANY. ANY REPRODUCTION IN PART OR AS A WHOLE WITHOUT THE WRITTEN PERMISSION OF THOGUS PRODUCTS COMPANY IS PROHIBITED.

C	95.00041	CONVERTED TO 3D FORMAT	UNLESS OTHERWISE SPECIFIED: DIMENSIONS ARE IN INCHES TOLERANCES: ANGULAR: ±0.5° X.X = ± 0.1 X.XX = ± 0.05 X.XXX = ± 0.015 REMOVE ALL SHARP EDGES AND BURRS BLEND ALL RADII TO 0.01IN INTERPRET GEOMETRIC TOLERANCING PER: ANSI Y 14.5 1994 MATERIAL: PP, P, N, K FINISH: NA THIRD ANGLE PROJECTION: 	NAME	DATE	Thogus You think it, we can make it... 33490 PIN OAK, AVON LAKE, OH 44012 TITLE: <b>BARB CONNECTOR, 5/8" X 5/8"</b>		
				DRAWN	KDJ		10/22/10	
				CHECKED	KDJ		10/22/10	
				ENG APPR.			XX/XX/XX	
				MFG APPR.			XX/XX/XX	
			Q.A.		XX/XX/XX			
REV	WRO#	DESCRIPTION	COMMENTS:			SIZE	DWG. NO.	REV
		HISTORY	DO NOT SCALE DRAWING			<b>B</b>	TC71010	<b>D</b>
						SCALE: 2:1	MASS:	SHEET 1 OF 1